

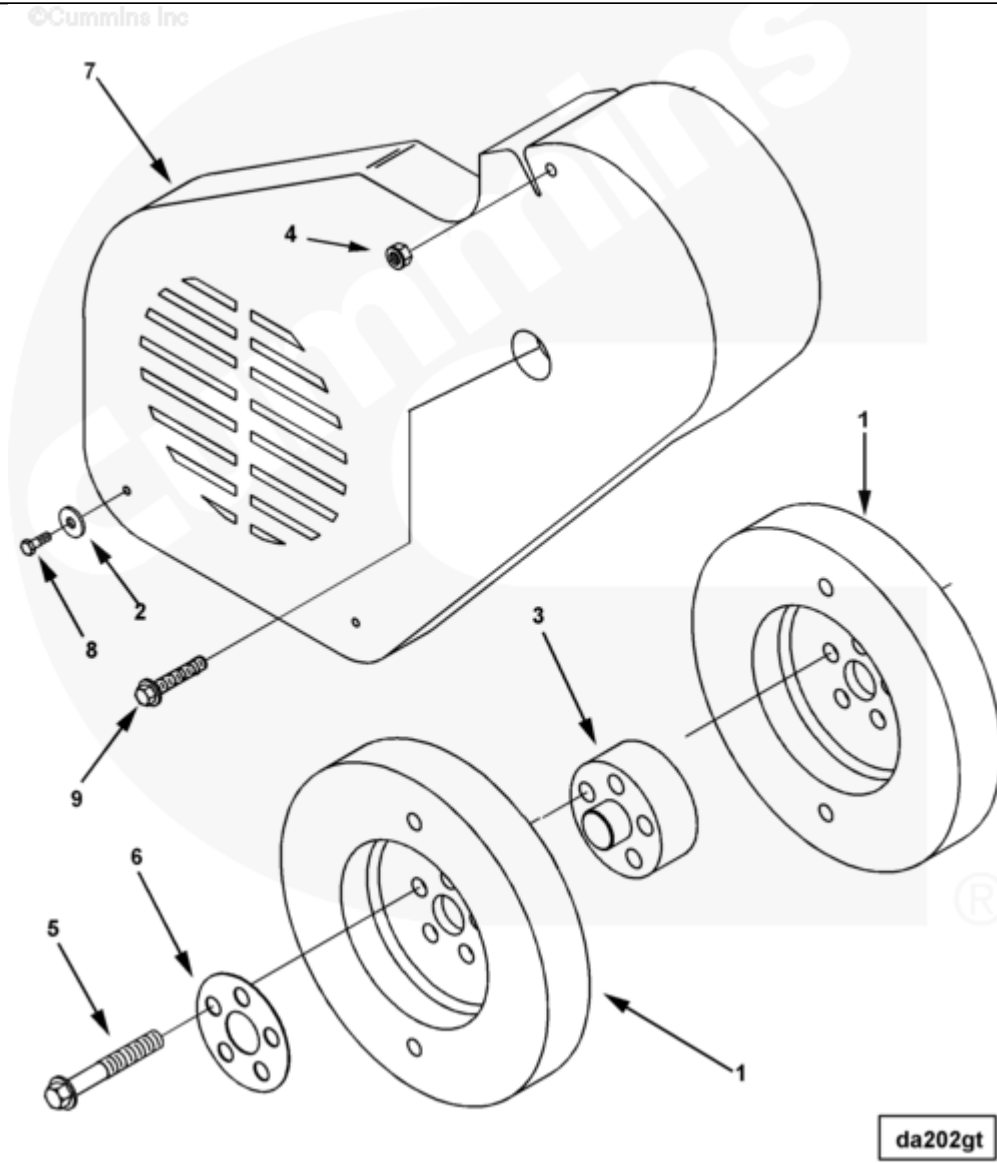

Parts Catalog - Option Detail

Electronic Parts Catalog - Option Detail				
Option	Group	Graphic	Film Card	Date
DA2108-02	01.02.2	da202gt	II	15-MAR-99
Engines	ISM CM570, ISM CM570/870, ISM CM875, ISM CM876, ISM CM876 E, ISM11 CM876 M103, ISM11 CM876 SN, M11 CELECT, M11 CELECT PLUS, M11 MECHANICAL, QSM11 CM570, QSM11 CM876			



SMALL | MEDIUM | LARGE

Cart	Ref No	Part Number	Part Description	Required	Remarks
View My Cart					
		DA2108-02	Vibration Damper		

					Vibration Damper
					Intended Drive: No Fan Drive
					Includes Viscous Vibration
					Damper Only. For No Future
					Fan Drive Provision
					Vibration Damper Quantity: Two
<input type="checkbox"/>	1	3161942	Viscous Vibration Damper	2	Recon equivalent 3161942 RX
<input type="checkbox"/>	2	3278499	Plain Washer	2	
<input type="checkbox"/>	3	3417651	Crankshaft Adapter	1	
<input type="checkbox"/>	4	3818824	Hexagon Flange Nut	1	M10 X 1.50.
<input type="checkbox"/>	5	3820513	Hexagon Flange Head Cap Screw	5	M14 x 1.50 x 100
<input type="checkbox"/>	6	3882675	Clamping Plate	1	
<input type="checkbox"/>	7	4003340	Front Engine Guard	1	
<input type="checkbox"/>	8	4019686	Hexagon Head Cap Screw	2	
<input type="checkbox"/>	9	4019687	Hexagon Flange Head Cap Screw	1	